

ENGLISH VERSION

1. BEFORE INSTALLATION

- Before connecting power cord to AC power outlet, open the cover case and remove packing (cushion) materials ① placed on ribbon cartridge section and hammer section as shown in Fig. 1.

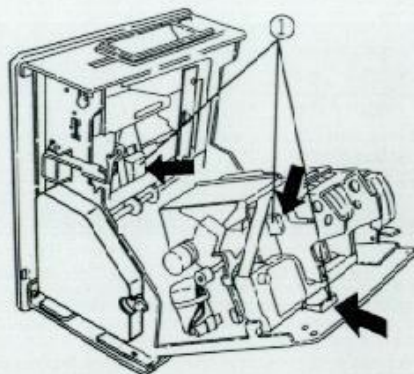

Fig. 1

2. INSTALLATION

- The clock may be table top or wall mounted.

For wall mounting the wall should be solid concrete or sturdy wooden structure. (Wood must be 3/4" or thicker.)

Minimum screw size for wooden wall:

Round Head Wood Screw
.. No. 10 X 1"
(5mm D x 25mm L)

For concrete wall use appropriate size lead screw anchors with the above wood screws.

For Power Resever Model apply collar (spacer) ⑥ on all 3 holes ⑤ between the wall and the back plate.

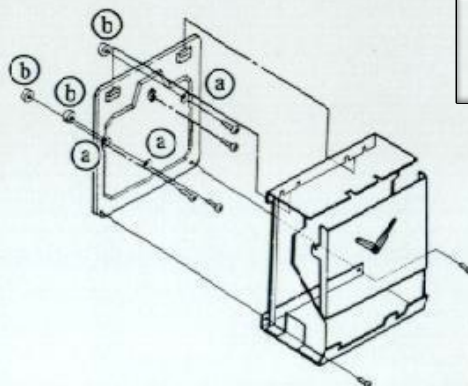

Fig. 2

3. HOW TO SET TYPEWHEELS

- (1) Remove the hook ③ in the direction of the arrow and pull out the shaft ②. Then lower the type and clock section as shown in Fig. 3.
- (2) Push the reset lever ③ and turn the setting knob ④ in the direction of arrow (as shown in Fig 4) until the desired time comes to the ditch on the side plates of typewheel section.
- (3) The time indicated on dial and the time printed should agree as the clock is geared to typewheels. Before putting back the type and clock section to the regular position, however, be sure that the time indicated agrees to time printed.
- (4) To set the day or date typewheel, push the reset lever ③ (as shown in Fig 4) and turn the typewheel ⑤ by hand as shown in Fig. 5.

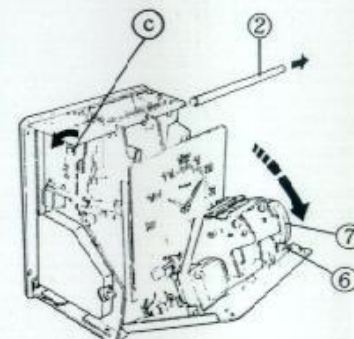

Fig. 3

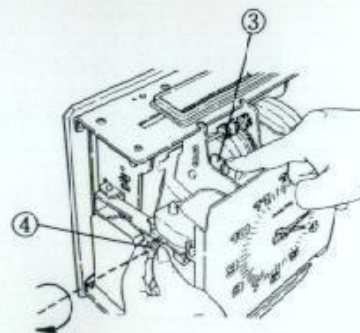

Fig. 4



Fig. 5



Central Time Clock

Since 1931

5-23 50th Ave

Long Island City, NY 11101

P: (718) 784-4900

www.centraletimeclock.com