

OPERATING INSTRUCTIONS, GUARDSMAN WATCHCLOCK

OPENING THE CLOCK

Unfasten the strap on the leather pouch and open the pouch. Insert the lock key in the lock and turn it 1/4 turn clockwise. Pull the cover open. Note; the key cannot be removed when the lock is open.

WINDING THE CLOCK

Wind the clock weekly on the same day. Place the key on the square arbor marked 'W' and turn it counterclockwise until fully wound. (One full winding will operate the movement for seven days).

SETTING THE HANDS

Use the same key to engage the square arbor marked 'S'. Turn the key in either direction to set the hands.

INSTALLING TAPE

Press the tape release. (The tape clamp will open). With a new tape, tear off the first few inches and insert tape roll into tape container with the perforations up. Engage the tape on the tape drive wheel and close the tape clamp.

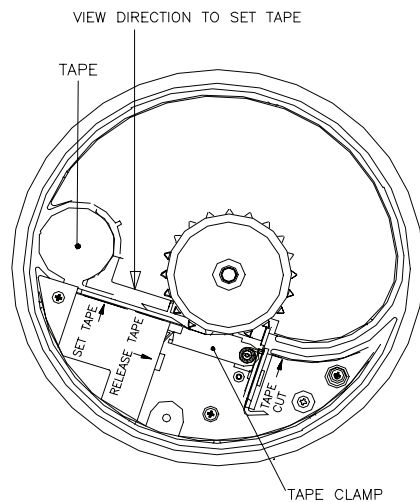

FIGURE 1

SET THE TAPE TIME

Turn the tape drive wheel counter-clockwise until the desired time appears in the tape set window. (See figure 2).

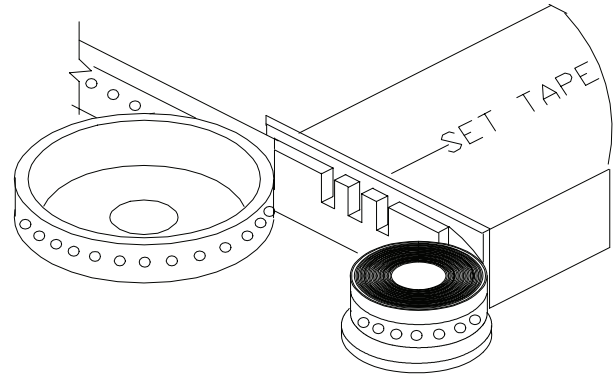

FIGURE 2

NOTE

INSURANCE CARRIERS REQUIRE DAILY REMOVAL AND INSPECTION OF TAPE EXCEPT OVER WEEKENDS AND HOLIDAYS.

Note also that, if used tape remains in the clock longer than 120 hours when the clock is running, it may cause the movement to bind and stop.

FILING USED TAPE

Used tape must be dated, initialed and filed for insurance company inspection.

REMOVING USED TAPE

Unlock and open the cover. Refer to figure 1 and push the tape cutter. Remove the cut portion.

CAUTION

To check a watchman's last round, you must allow a minimum of five hours after completion of the round before you cut the tape.

TELL-TALE

When the clock is opened or closed, a perforation is made on the top edge of the tape, showing the exact time that the clock was opened or closed. There should be one perforation when the clock was opened to remove the used tape or to load a new tape. Any perforation between the scheduled tape removal indicates unauthorized opening of the clock.

TAPE USAGE

For tape or service, contact your distributor. Keep an adequate supply of tape on hand to avoid an outage.