

## TS3000i Time Stamp – Trouble Shooting Procedures

### **P1: Paper is inserted to time stamp but unit does not print.**

Tilt time stamp back to view bottom of time stamp as shown below. See Print method selector (A) and margin adjuster (B).

Check Print selector is set all the way to left, to the "P" setting.

Move margin adjuster to half way up track towards front of unit.

Attempt to punch – If unit does not punch continue to **P3**.

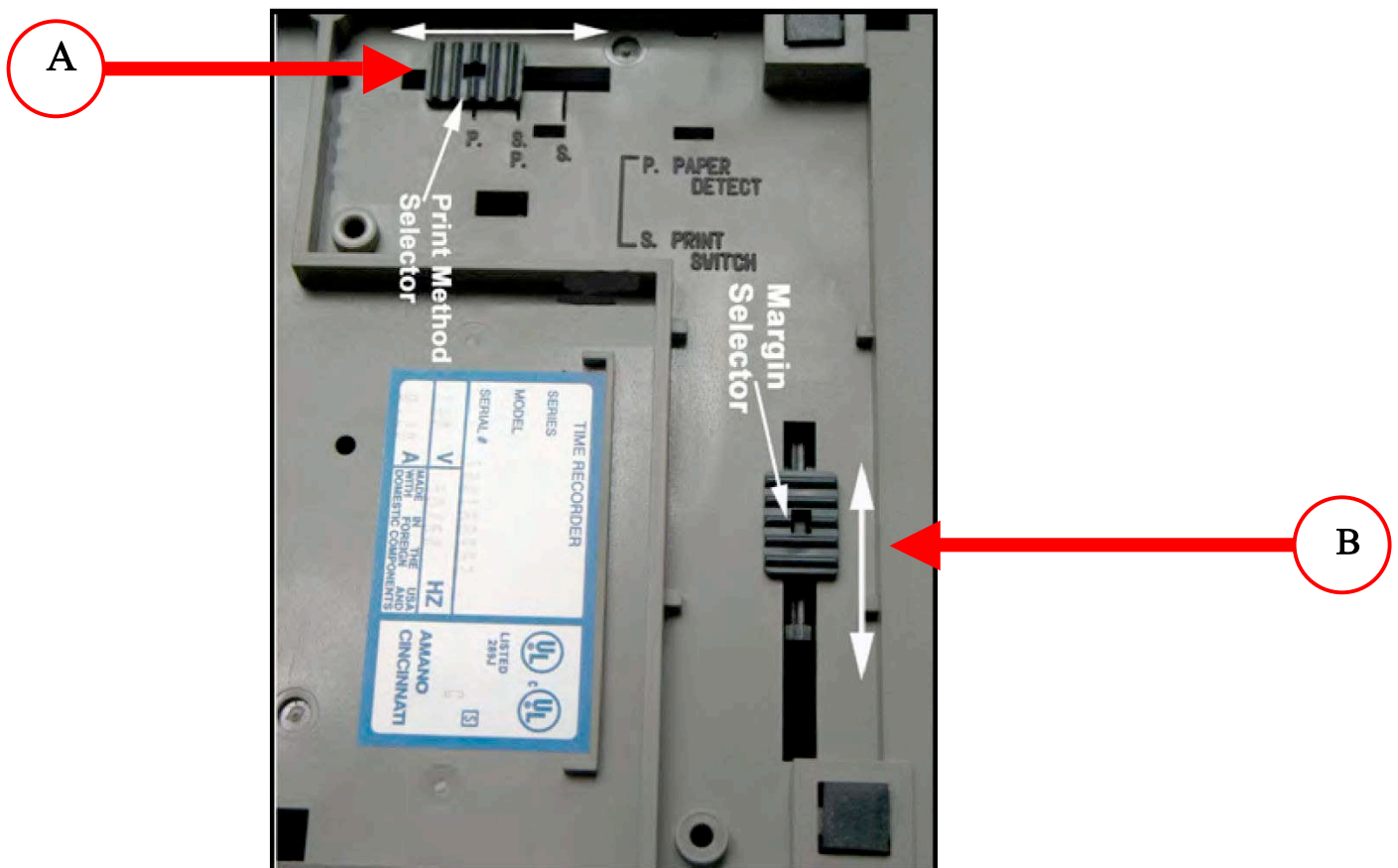

**P2: LCD is blank and unit does not punch**

Check black power cord is connected to outlet is receiving power  
Remove top case as per below

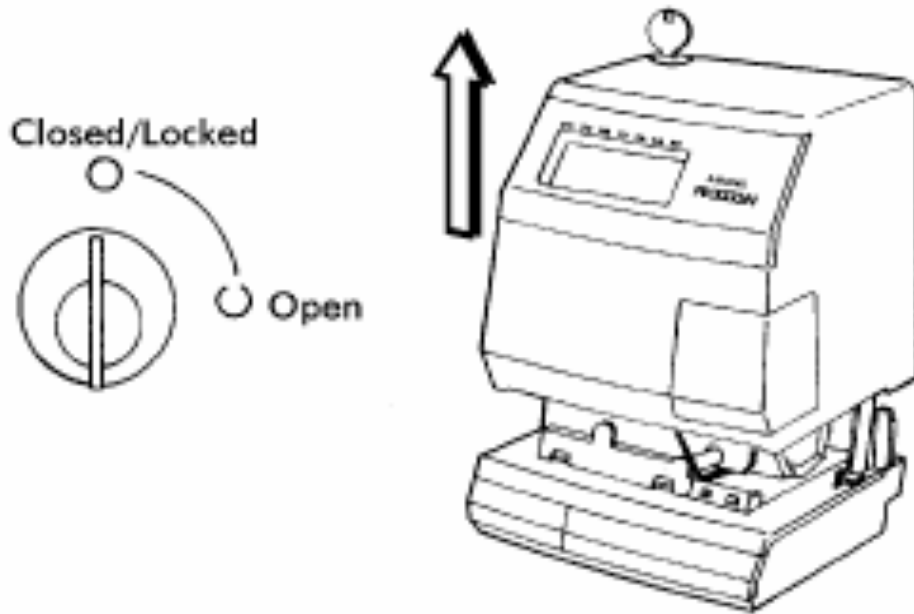

**Arrows flashing under the days of the week and unit is printing a black box at end of print string in lieu of the standard (s):**

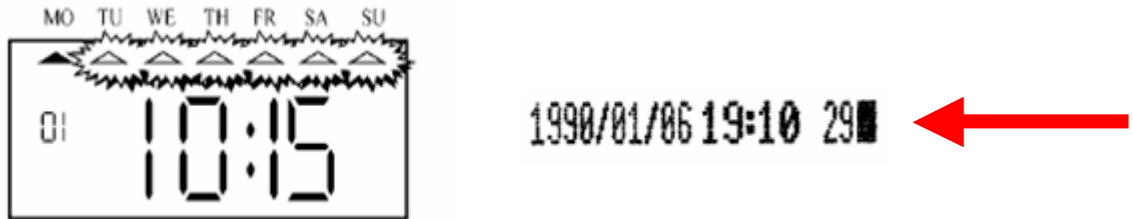

**Arrows flashing indicates your clock has not received with in the last 24 hours or it is not connected to the network.**

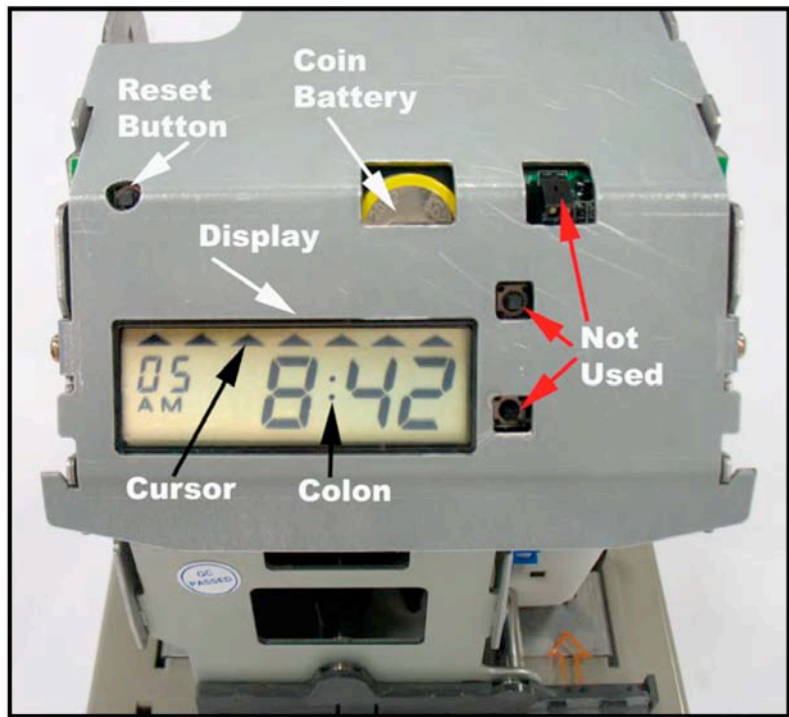

Remove top case of unit as show in **P2** (**P6** to replace case):  
 Press reset button above LCD on front left of unit, as per below: (Note if unable to locate key to access reset button – remove black time stamp three prong power cable from and reconnect, this may reset unit as well)

E1 Pr. E2 Pr. E3 Pr. E4 Pr. Er Pr	Printer jam	<ol style="list-style-type: none"> <li>1. Remove cover and set the PIX on its side with ribbon side up.</li> <li>2. Press the <b>RESET</b> button to reset the <b>Printer Carriage</b>.</li> <li>3. Blow air into <b>Printer Platen</b> to remove or dislodge jammed objects.</li> </ol>
--------------------------------------	-------------	--

### P3

#### **P3: Print carriage is stuck down and/ or LCD shows arrow flashing or E1-E4 Prt Err :**

Remove top case of unit as show in **P2** (**P6** to replace case):  
 Press reset button above LCD on front left of unit, as per below: (Note if unable to locate key to access reset button – remove black time stamp three prong power cable from and reconnect, this may reset unit as well)

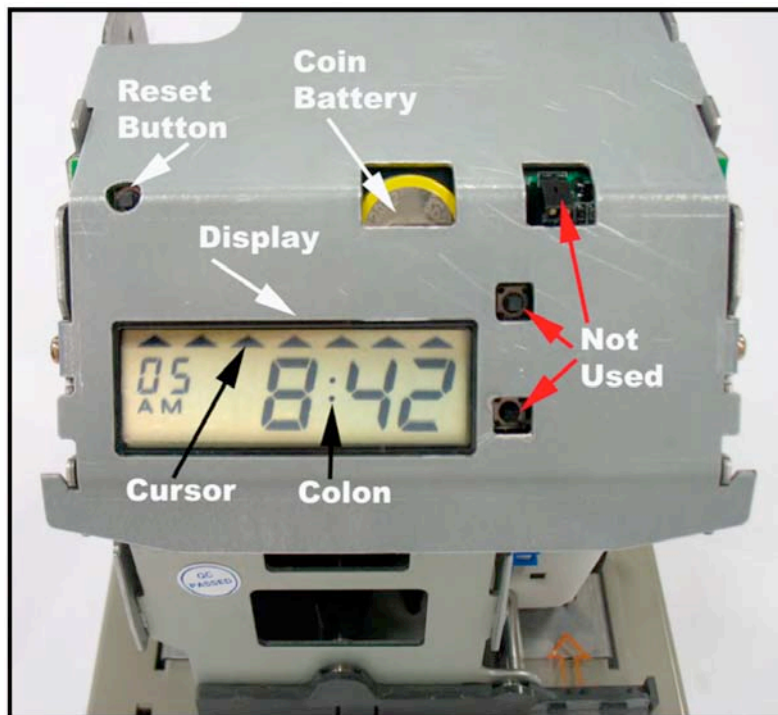

#### **P4: Imprint is printing off edge of ticket:**

Tilt unit back to view bottom of unit. Move **margin selector** to desired position, toward back of unit as shown below: (See figure below)

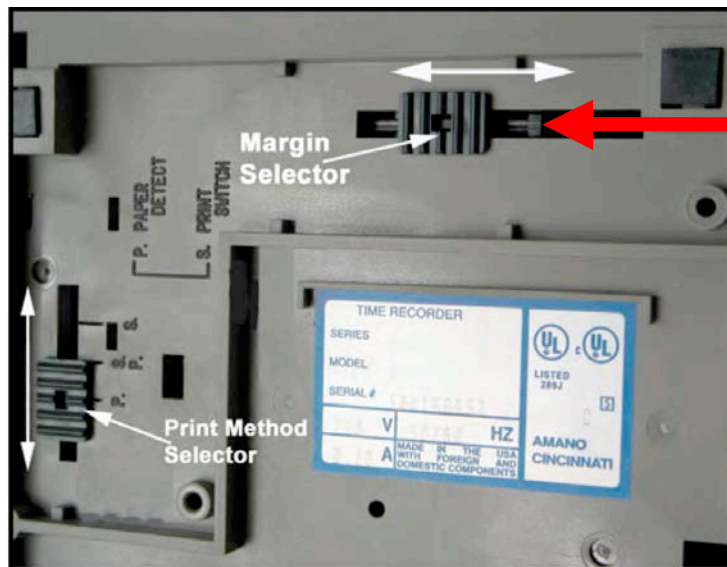

#### **P5: Print becoming light:**

##### **Replacing the Ribbon**

###### **Removal**

1. Remove the cover (see **P2**).
2. Looking at the right hand side of the machine, pull the two catches (B) upward. While holding the catches up, use your other hand to remove the ribbon.

###### **Installation**

1. Insert the top of the ribbon first.
2. Swing the lower portion of the ribbon into position.
3. Turn the knob on the ribbon two or three times to reduce any slack in the ribbon.
4. Replace the cover (**P6** to replace case).

If during procedure print carriage becomes jammed down so that paper can not be inserted, follow **P3**.

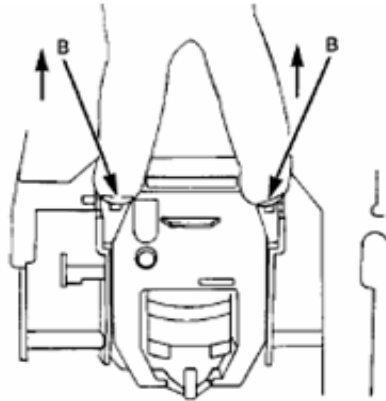

## **P6: Closing the Cover**

Ensure all cables on rear of unit are not impeding case from closing. Replace PIX3000XNT cover on clock, being careful not to pinch any cables. Turn the key counter clockwise to lock the cover. **DO NOT FORCE KEY TO LOCKED POSITION**, if resistance is encountered – lift case and try to shift obstruction.

